

Bicycle Owner's Manual

Multi Speed Bicycles

The following manual provides assembly and maintenance instructions, as well as a guide to safe usage of your new bicycle.



WARNING

- Read the complete Owner's Manual before starting the assembly of this bicycle.
- Rider of this bicycle must wear a helmet at all times.

Don't return this product to the store if you need replacement parts or have a question regarding assembly of this product. Please call our SERVICE CENTRE direct on

1800-632-792



Table of Contents

	Page
Safety Information	2
Bicycle Identification	3
Fitting the rider to the bicycle	3
Rules of the road	4
Wet weather riding	5
Introduction to the manual	6
Front wheel assembly	7
Front wheel quick release assembly	8
Front reflector assembly	11
Rear reflector assembly	14
Spoke reflectors	16
Handlebar and stem assembly	18
Seat assembly	22
Pedal attachment	25
Kickstand	26
Brake systems	27
Brake pad replacement	33
Gears: How to operate	36
Chain	40
Lubrication	41
Service checklist	42
Recommended torque	43
Tyres	44
Suspension frames	45
Inspection on bearings	46
Parts order	47
Exploded diagram	48
Warranty	49

Owner's Safety Information and Responsibilities



During this manual you will read many WARNINGS, CAUTIONS or NOTES, please pay special attention to these throughout.

WARNING: This is shown with personal safety instructions, failure to follow these may result mechanical failure or damage.

CAUTION: This is shown with mechanical instructions; failure to follow these may result in injury to the rider or others.

NOTE: This is shown to highlight a specific point of interest, which will help in the assembly or maintenance of this bicycle.

The Owner's Responsibility

- If the bicycle was purchased unassembled, it is the responsibility of the owner to follow all the assembly and adjustment instructions exactly as written in this manual.
- If your bicycle was purchased assembled, it is the owners responsibility to read and make sure bicycle was assembled as shown in this manual.
- Know how to use all standard and accessory equipment on the bicycle.

WARNING This bicycle is made to be ridden by one rider at a time for general transportation and recreational use. It is not made to withstand the abuse associated with stunting and jumping.

Bicycle Identification Record

Each bicycle has a Model / Serial Number stamped into the bottom of the frame. Write this number below to keep it for future reference. If the bicycle is stolen, give this number and description of the bicycle to the police.

You will also need this number if you orders parts or request service information.

Model / Serial Number.....

Purchase Date.....

Purchase Location.....

Model Name.....

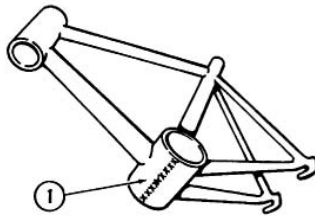

Fitting the Rider to the Bicycle



To determine the correct size of bicycle for the rider:

- Straddle the assembled bicycle with feet shoulder width apart and flat on the ground
- There must be at least 25.4mm of clearance between the top of the tube and the crotch of the rider.

Rules of the Road



WARNING Failure of the rider to obey the following “Rules of the Road” can result in injury to the rider or to others.

- Obey the road rules at all times, such as traffic signals, signs and giving way to pedestrians.
- Always wear a bicycle helmet that meets the local safety standards.
- Always ride in the same direction as the traffic. Never ride against traffic.
- Avoid the following hazards: drain grates, soft road edges, gravel or sand, pot holes or ruts, wet leaves, or uneven paving.
- When crossing railroad tracks do so carefully at a 90 degree angle to prevent loss of control.
- Do not carry packages or object that obstruct your vision or control.
- Do not carry any passengers.
- Do not ride with both hands off the handlebars.
- Use hand signals. Indicate intended actions, such as turning or stopping, by using appropriate hand signals.
- Apply the rear brake first, then apply the front brake. The front brake is more potent and if not used properly you may lose control and fall.
- Do not use items that may impede your hearing. Eg headphones
- Ride predictably and in a straight line.

Night Riding

- Avoid riding at night if possible, if you choose to ride at night:
- Purchase, install, and use a front and rear bicycle light.
- Make sure the reflectors of your bicycle are correctly positioned.
- Use a flashing rear light to improve visibility.
- Wear light-coloured reflective clothing, such as a reflective vest and reflective bands for your arms and legs.

Wet Weather

- Use extra caution in wet weather.
- Avoid sudden braking.
- Apply brakes sooner in wet conditions, as stopping distance increases in wet weather.
- Slow overall riding pace and approach corners more carefully.

Off-Road Riding

- Use extreme caution when not riding on pavement.
- Always wear correct safety equipment.
- Ride only on the trails.
- Avoid rocks, branches, or depressions.
- When approaching a descent, reduce speed, keep your weight back and low, and use the rear brake more than the front.
- Be sensitive to the environment, conscientious of the property on which you ride, and considerate of others you may meet on the trail.

Introduction and How to use this Manual

This owner's Manual is made for several different bicycles. The illustrations used are to provide examples and some may not look exactly like the parts of the bicycle, but the instructions are correct. In addition some of the parts shown might be optional and not part of your bicycle's standard equipment. If the bicycle has any parts that are not described in this manual, look for separate "*Special Instructions*" that are supplies with the bicycle. Make sure the rear wheel is centered in the bicycle frame.

Unpacking

Remove the bicycle from and all parts from the carton. Do not dispose of the carton and packaging until you complete the assembly of the bicycle. This can prevent accidentally discarding parts of the bicycle.

NOTE: All of the directions (right, left, front, rear, etc) in this manual are as seen by the rider while seated on the bicycle.

Tools Needed for Assembly



15cm Adjustable wrench



25cm Adjustable wrench



Flat Blade Screwdriver



Phillips Screwdriver

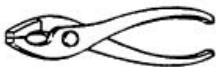

Slip Joint Pliers



Metric Allen Wrenches
(Needed on some models)



Torque Wrench

Step 1

Front Fender Assembly

NOTE: If Bicycle does not have a front fender, go to Step 2.

1. With the fork turned forward, lean the bicycle against the wall.
2. Place the fender in the fork with the upper mounting tab on the rear side of the fork.
3. Secure with mounting bolt, lock washer and Nylon nut.
4. Tighten each screw sufficiently to hold the fender in place, be careful not to over tighten and strip the screw threads.

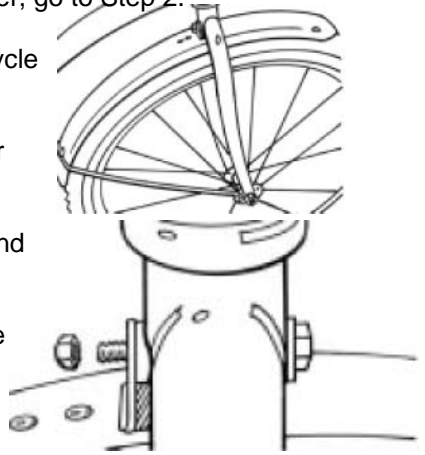

Step 2

Front Wheel Assembly

(Recommended torque is 22-17 Nm)

1. Remove plastic axle protectors off the wheel axle and dispose of them. They are for shipping purposes only.
2. Slide wheel axle into the open ends of the Front fork.
3. Slide a wheel retainer (6) onto each end of the axle. Ensure the tab of each retainer is in the hole in the frame.
4. Install an axle nut (7) loosely onto each end of Axle.
5. Center the wheel in the fork and tighten both nuts securely to the recommended torque, alternating from one to the other.

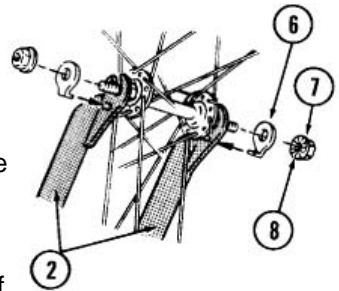

NOTE: Some models are shipped with the reflector installed facing between the front forks to protect it when shipping. If so please remove reflector and rotate it 180 degrees and install again before inserting the wheel between the front forks.

Step 3

Front Wheel Quick Release Mechanism Assembly

NOTE: If Bicycle does not have a quick release wheel, go to next step

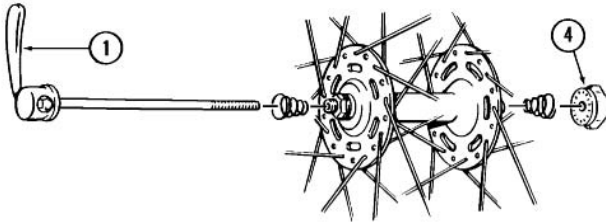

A. Assemble the quick release mechanism to the front wheel:

1. Remove the adjusting nut (4) and one spring from the quick release mechanism.
2. Put the quick release mechanism through the front wheel hub
3. Put the spring and adjusting nut back on the quick release mechanism
Do not tighten the adjusting nut at this time.

B. Assemble the front wheel to the fork:

NOTE: The words “open” and “close” are on opposite sides of the quick release lever.

1. Move the quick release lever (1) to the “open” position (2) so the word “open” is pointing away from the wheel
2. Put the wheel between the fork legs (3). Make sure the axle is against the bottom of the slot in each fork leg.

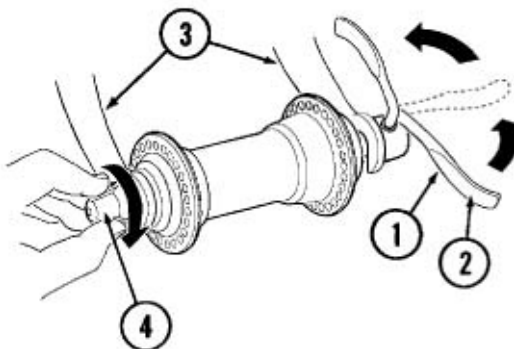



WARNING: Failure to obey these steps can allow the front wheel to loosen while riding. This can cause injury to the rider or to others.



CAUTION: Operate the quick release lever by hand only. Do not use a hammer or any other tool to tighten the quick release lever.

C. Adjust and tighten the quick release mechanism:



WARNING: Do not tighten the quick release mechanism by turning the lever in a circular motion. This causes the clamping force to be too tight.

You must use strong force to move the quick release lever to the “close” position. If you can easily move the lever to the “close” position, the clamping force is too light.

If the clamping force of the quick release mechanism is too light, the front wheel can loosen while riding. This can cause injury to the rider or to others.

- If the fork of your bicycle has a wheel retainer attached, move the wheel retainer so it is under the adjusting nut or quick release lever.
- Open and close the quick release lever with one hand while you turn the adjusting nut with the other hand
- Tighten or loosen the adjusting nut by hand, so that you first feel resistance to the quick release lever when it is parallel with the axle.
- Put the wheel in the center of the fork and with strong Force, push the cam lever to the “close” position (5)
- When in the “close” position, make sure the quick release lever lays along the fork

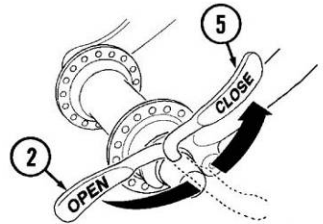

Operation

To remove wheel:

- Move the quick release lever to the “open” position
- It is not necessary to turn the adjusting nut to remove the wheel.

Before riding the bicycle:

- Especially after parking in a public place, always check that the quick release mechanism is properly installed and tightened.
- If you are not certain that the quick release mechanism is correctly installed and tightened, repeat steps in the previous instructions.
- Make sure the quick release lever is pushed fully to the “close” position.

Step 4 Front Reflector Bracket and Clear Reflector Assembly

This section covers the assembly of the front reflector to the front reflector bracket. Determine which style you have before beginning assembly.

Snap in Style



Reflector Assembly

Screw In Style

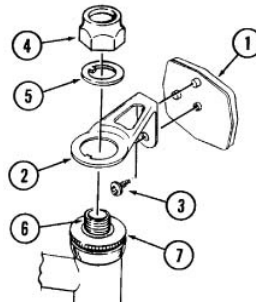

1. Assemble the clear reflector to the front reflector bracket:



WARNING: Install the clear reflector exactly as shown or it will not operate correctly

Snap In Style

- Push the reflector onto the reflector bracket.
- Make sure the stud on the reflector goes into the hole of the bracket with a “snap” sound.

Screw In Style

- Put the reflector onto the reflector bracket
- Make sure the studs on the back of the reflector go into the holes of the reflector bracket.
- Put the screw through the bracket and into the reflector
- Tighten screw

Front Reflector Bracket Installation

This section covers several different placements of the front reflector bracket. Make sure the front reflector is vertical (perpendicular to the ground)

The front reflector bracket will mount on the fork or handlebar. Some models may already have the brackets and reflector installed. If the reflector is not installed, refer to the “Front Reflector Bracket and Clear Reflector Assembly” section.

Determine which type of reflector bracket you have and it’s mounting location and then follow the instructions for that style.

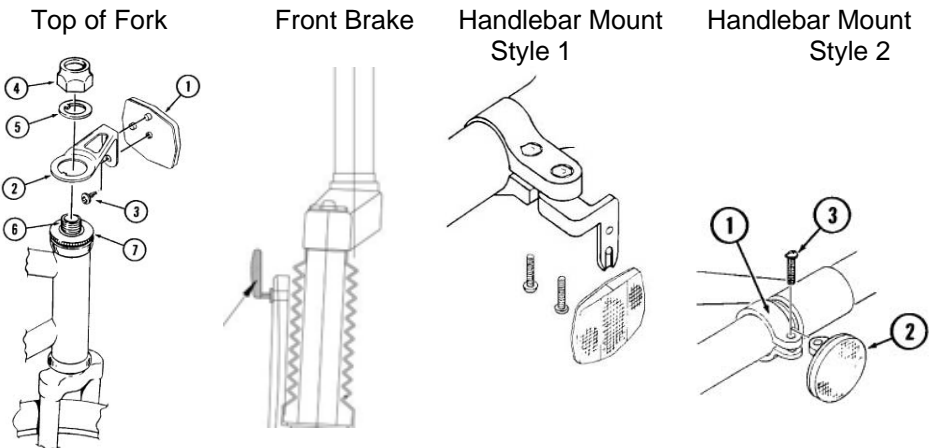

Top of Fork

1. Attach the hardware to the fork:

- Remove and discard the plastic cap (5) (if installed) on fork (6)
- Tighten bearing cone (7) by hand to make sure the bearings are tight
- Install reflector bracket and locknut (8)
- Tighten locknut

Front Brake

1. Attach the hardware to the fork:

- Place the bracket over the front brake. Ensure that you install correct way with the reflector facing up.
- Secure with Phillips head screw provided.

NOTE: On some models the front reflector is pre-installed, but rotated so the it is facing between the forks to protect it during shipping. If so, before attaching the front wheel you will have to remove the reflector, turn it around and install again using the above steps.

2. Assemble the front reflector bracket and clear reflector to the fork:

- Attach the reflector bracket to the front of the fork with a bolt (9) and self locking nut (10)
- If necessary, adjust the angle of the front reflector bracket so the clear Reflector is vertical (perpendicular to the ground)

Handlebar Mount – Style 1 and Style 2

1. Assemble to the handlebar:

- Put the clamp (1) as near the handlebar stem as possible

NOTE: If you have Style 1, make sure the bracket points towards the ground.

- Hold the reflector in this position and tighten the screw(s) (3)

Operation and Maintenance



WARNING: For your own safety, do not ride this bicycle if the reflectors are incorrectly installed, damaged, or missing. Make sure the front and rear reflectors are vertical. Do not allow the visibility of the reflectors to be blocked by clothing or other articles. Dirty reflectors do not work well. Clean the reflectors, as necessary, with soap and a damp cloth.

Rear Reflector Bracket and Red Reflector Assembly

This section covers the assembly of the rear reflector to the rear reflector bracket. Determine which style you have before beginning assembly.

Snap In Style



Reflector Assembly

1. Assemble the red reflector to the rear reflector bracket:



WARNING: Install the red reflector exactly as shown or it will not operate correctly.

Snap In Style

- Push the reflector (1) onto the reflector bracket (2)
- Make sure the stud (3) on the reflector goes into the hole (4) of the bracket with a “snap” sound.

Screw In Style

- Put the reflector onto the reflector bracket
- Make sure the studs on the back of the reflector go into the holes of the reflector bracket
- Put the screw through the bracket and into the reflector
- Tighten screw.

Step 5

Rear Reflector Bracket Installation

This section covers several different placements of the rear reflector bracket. Make sure the rear reflector is vertical (perpendicular to the ground)

The rear reflector bracket will mount on the seat post, post clamp, or rear brace. Some models may already have the brackets and reflectors installed. If the reflector is not installed, refer to the “Rear Reflector Bracket and Red Reflector Assembly” Section.

Determine which type of reflector bracket you have and it’s mounting location and then follow the instructions for that style.

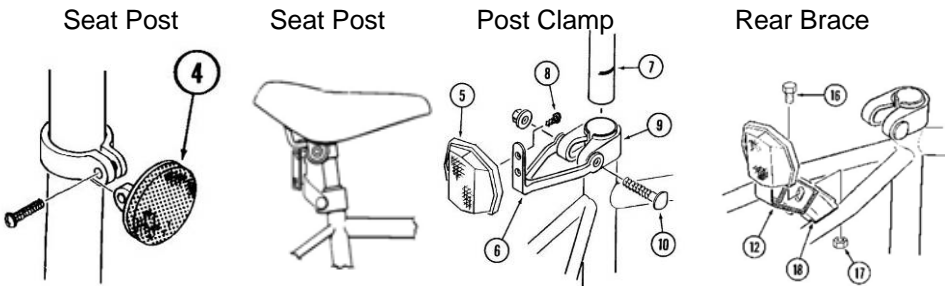

Seat Post

1. Assemble the reflector bracket to the seat post:

- Make sure the red reflector (4) is vertical, points toward the rear of the bicycle, and has 7.5cm of clearance between the top of the seat and the top of the red reflector.
- Hold the red reflector in this position and tighten the screw(s).

Post Clamp

1. Put the rear reflector bracket on the post clamp:

- Make sure the rear reflector bracket points up
- Put the bolt through the reflector bracket and the post clamp (8)
- Install nut (or nut and washer)
- Do not tighten at this time.

Rear Brace

1. Install bracket on rear brace:

- Put bracket on brace so the bracket points up
- Install bolt and nut (also washer, if provided)
- Tighten securely

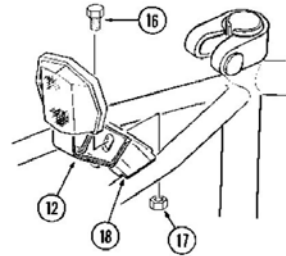

WARNING: For your own safety, do not ride the bicycle if the reflectors are incorrectly installed, damaged, or missing. Make sure the front and rear reflectors are vertical. Do not allow the visibility of the reflectors to be blocked by clothing or other articles. Dirty reflectors do not work well. Clean the reflectors, as necessary, with soap and a damp cloth.

Spoke Reflectors

Your bicycle may have one of the following styles of spoke reflectors. Many bicycles will come with the wheel reflectors already attached. If your bicycle does not have the wheel reflectors attached, determine which style you have and follow the instructions.

Style 1 – Bolt and nut

1. Assemble a reflector between the spokes of each wheel:

NOTE: If the bicycle has a wheel disc, put the reflector in the notch of the wheel disc. The notch is shaped so the spoke reflector fits into it.

- Make sure the center of the each reflector (1) is less than three inches from the inside edge of the wheel rim (2)
- Make sure the curve of the reflector (3) matches the curve of the wheel rim (4)
- Install bolt and nut, then tighten.

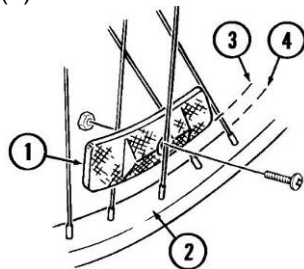

Style 2 – Push pin

- Put fastener (6) over a spoke (7) and into each reflector.
- Push pin straight into reflector until a “snap” sound is heard.

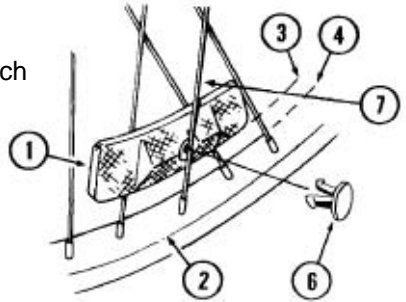

Style 3 – One-quarter turn

- Put fasteners (6) over a spoke (7) and into each reflector
- Turn fasteners clockwise one-quarter of a turn

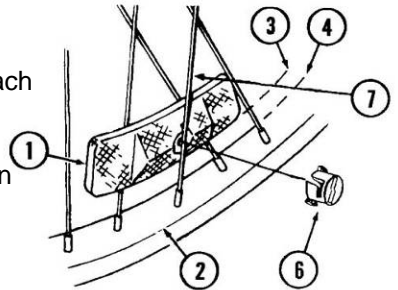

Operation and maintenance



WARNING: For your own safety, do not ride the bicycle if the reflectors are incorrectly installed, damaged, or missing. Make sure the front and rear reflectors are vertical. Do not allow the visibility of the reflectors to be blocked by clothing or other articles. Dirty reflectors do not work well. Clean the reflectors, as necessary, with soap and a damp cloth.

Step 6 Handlebar and Stem Assembly

The bicycle may have different styles of handlebar stems. One style mounts inside the fork while the other mounts around the outside of the fork. Follow the instructions for the style that you have.

Assembly

1. Assemble the stem to the fork:

Inside mount style

- Insert the stem into head set lock nut.
- The handle bar clamp should face towards the front of the bicycle

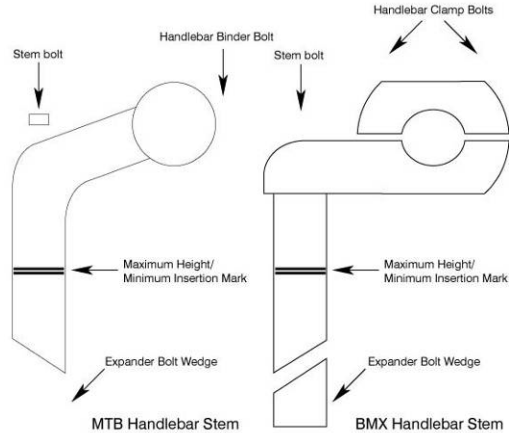

WARNING: Etched on the stem is a mark about 65mm up from the bottom with the words 'max height' or "minimum insertion". Never ride a bicycle if the stem has been raised so that this mark can be seen.

- At this stage tighten stem bolt just enough to hold it in position.

Outside mount style

- If necessary, loosen the top bolt (1) of the stem (2) and the Stem_bolt (s) (3) only just far enough so the stem can turn on the fork.

- Point the stem toward the front of the bicycle
- Tighten the top bolt of the stem
- Tighten the stem bolt(s) equally

2. Assemble the handlebar to the stem:

- Insert the handlebar (5) into the stem, but do not tighten the handlebar Clamp (6) at this time.

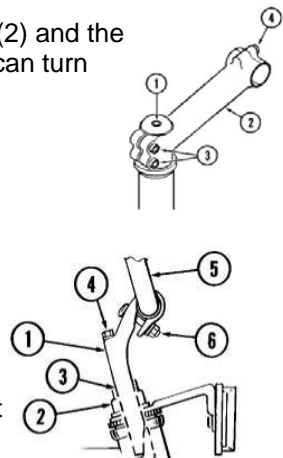

3. Determine the type of parts to be assembled to the handlebar:

Some models of bicycles require additional parts to be installed onto the handlebars. The following are the various combination of parts that you may have to assemble. You may not have some of the parts but assemble the parts you have in the order as shown.

NOTE: If Bicycle does not have these extra parts or are already installed, go to next step

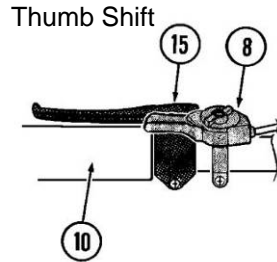
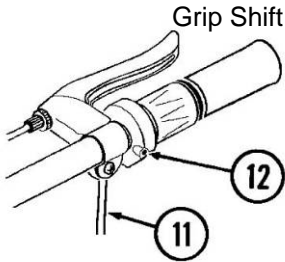

- Make sure the brake lever to the front brake is mounted on the right side of the handle bar
- Install the safety bell onto the handlebar, secure with bolt provided.
- Make sure the shifter to the rear derailleur is mounted on the right side of the handlebar
- Install grips using a mixture of five drops of liquid soap in a cup of water



WARNING: Use only soap and water to install the grips. The grips may slip while wet. Allow grips to completely dry before riding the bicycle.

- Wet the handlebar and the inside of each grip (1) with the soap mixture
- Using a twisting motion, push each grip fully on the handlebar
- If you have bar ends, make sure they are fully on the handlebar
- If the grips are open on both ends, push a plastic plug (11) into each end of the handlebar (you may need a rubber mallet for this).

4. Tighten the stem bolt and handlebar clamp

(Recommended torque is 17-19 Nm)



WARNING: Do not over tighten the stem bolt. Over tightening the stem bolt can damage the steering system and cause loss of control.

- Make sure the stem is aligned with the front wheel and tighten the stem bolt
- Position the handlebars in the desired position of the rider. Ensuring they are facing the correct direction.



WARNING: If the handlebar clamp is not tight enough, the handlebar can slip in the stem. This can cause damage to the handlebar or stem, and can cause loss of control.

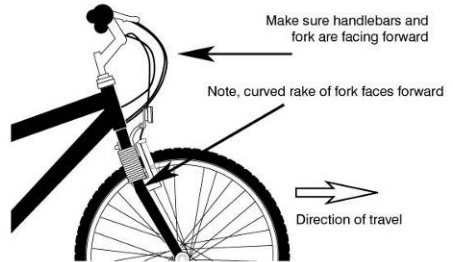

- Tighten the bolt(s) of the handlebar clamp
 - If the handlebar clamp has more than one bolt, tighten the bolts equally.

5. Test the tightness of the stem bolt and handlebar clamp:

- Brace the front wheel between your knees and try to move the handlebars up and down and from side to side. The handlebars are secure within the stem and the stem within the fork steer tube if no movement is detected when applying turning pressure.

6. Put the handlebar parts in the correct position:

- Put the brake lever and shift control in a position that is comfortable to the rider
- Make sure the brake levers do not touch the grip or the shift control during use
- If you have a grip shift control, the clamp screw for the control is in a recess on the side on the end nearest the stem.
- Tighten the clamp screw of each brake lever

- Move each bar end around the handlebar to a position that is comfortable to the rider
- Tighten the clamp bolt of bar end securely.

7. Test the tightness of the handlebar ends:

- Hold the bicycle stationary and try to move the ends of the handlebar ends forward and backward
- If either handlebar end moves on the handlebar, reposition it and tighten the clamp bolt tighter than before
- If the handlebar moves in the stem, loosen the stem clamp, reposition the handlebar, and tighten the handlebar clamp tighter than before
- Do this test again, until the handlebar ends and the handlebar do not move.

8. Put each brake lever in the correct position:

- Put each brake lever in a position that is comfortable to the rider
- Tighten the clamp screw of each brake lever.

Operation



WARNING: If you choose to ride with your hands on the handlebar ends, be careful. You will not be able to stop quickly because your hands are farther away from the brake levers.

Step 7 Seat Assembly



NOTES: If you accidentally drop the seat post into the seat tube, you may not be able to remove it.

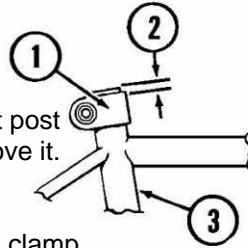

1. Install post clamp on the seat tube:

- Put the clamp on the seat tube. Push the clamp (1) down so you can see 1.6mm (2) of the seat tube (3) above the clamp.

NOTE: Some post clamps are welded in position and can not be removed.

- If the post clamps has a raised edge, make sure the raised edge is against the top of the seat tube.

2. Attach the seat to the seat post or seat pillar:

(Recommended torque is 12-17 Nm)

- Position the seat post into the clamp under the saddle.
- Tighten the seat clamp so the seat (12) stays on the seat post
- If the seat clamp has nuts on each side, tighten both nuts equally

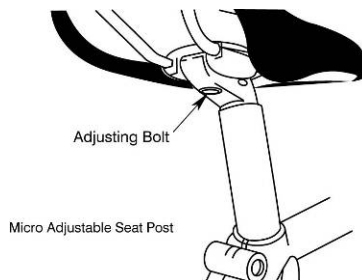
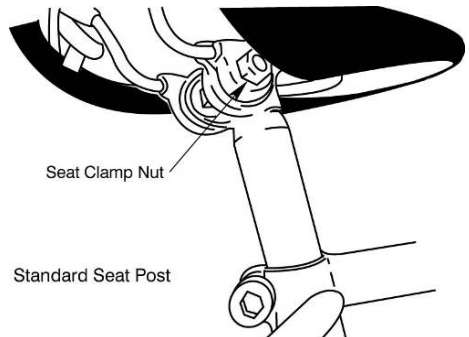

3. Attach the seat post into the seat tube

(Recommended torque is 15-19 Nm)

- Point the seat forward and insert the seat post into the seat tube.
- Make sure you can not see the “MIN-IN” minimum insertion mark of the seat post above the seat tube.
- If a seat post clamp is included slide this onto the seat post.
- Put the seat at a comfortable height for the rider.



WARNING: Never ride a bicycle with the minimum insertion mark visible on the seat post. Doing so may damage the seat post, the frame or cause injury to the rider.



WARNING: The red reflector must be vertical, point straight toward the rear of the bicycle, and have three inches of clearance between the top of the seat and the top of the red reflector.

- Tighten the bolt or quick release lever to the recommended torque
- To tighten the quick release lever:
- Move the quick release lever to the “open” position so the word “open” is pointing away from the post clamp.

NOTE: The words “open” and “close” are on opposite sides of the quick release lever.



CAUTION: Operate the quick release lever by hand only. Do not use a hammer or any other tool to tighten the quick release lever.

You must use strong force to move the quick release lever to the “close” position. If you can easily move the lever to the “close” position, the clamping force is too light.

If the clamping force of the quick release is too light, the seat post or seat pillar can loosen while riding. This can cause injury to the riders or to others.

- Open and close the quick release lever with one hand while you turn the adjusting nut with the other hand.

- Tighten or loosen the adjusting nut by hand, so that you first feel resistance to the quick release lever when it perpendicular to the bicycle frame.
- Push the quick release lever to the “close” position
- When in the “close” position, make sure the quick release lever lays along the seat tube
- The tightening torque of the quick release lever should be between 43 and 65 in.-lbs.

4. Test the tightness of each the clamp and the post clamp:



WARNING: Every time you loosen the quick release mechanism, make sure the red reflector is correctly positioned if the reflector is mounted on the seat post or seat pillar.

- Try to turn the seat side-to-side and to move the front of the seat up and down
- If the seat moves you need to further tighten the binder bolt
- Loosen the seat clamp
- Put the seat in the correct position and tighten the seat clamp tighter than before
- Do this test again, until the seat does not move in the seat clamp
- If the seat post moves in the seat tube:
- Loosen the bolt and nut
- If you have a quick release lever, move it to the “open” position
- Put the seat in the correct position and tighten the bolt and nut or quick release tighter than before
- If you have a quick release lever, move the lever to the “close” position
- Do this test again, until the seat post does not move in the seat tube.

Step 8 Pedal Attachment

(Recommended torque is 24-30 Nm)



CAUTION: There is a right pedal marked “R” and a left pedal marked “L”. Please ensure you assemble them on the correct side.

The pedal marked “R” has right-hand threads. Tighten it in a clockwise direction.

The pedal marked “L” has left hand threads. Tighten it in a counterclockwise direction.

1. Turn the right pedal marked “R” (1) into the right side of the crank and the left pedal marked “L” (2) into the left side of the crank.

2. Tighten the pedals:

- Make sure the threads of each pedal are fully into the crank
- Tighten both pedals to the recommended torque

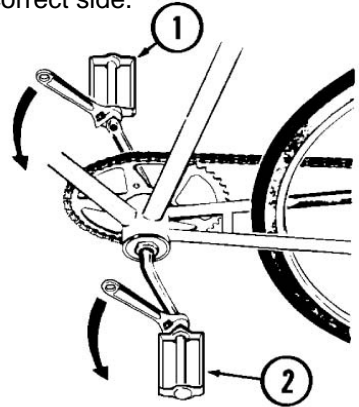

Kickstand

If your model does not already have the kickstand attached, determine which kickstand looks most like the one you have and follow the instructions.



CAUTION: Do not sit on the bicycle with the kickstand down. Damage to the kickstand and frame can occur.

Crank Mount

Assemble the kickstand to the bicycle frame:

- Put the kickstand (1) under the bicycle frame
- Assemble the hardware to the kickstand and the bicycle frame
- Align the kickstand with the bicycle frame
- Tighten hardware securely
- The kickstand may be adjustable. Loosen screw (2) and move kickstand in or out so bicycle is stable when standing.
- Tighten screw.

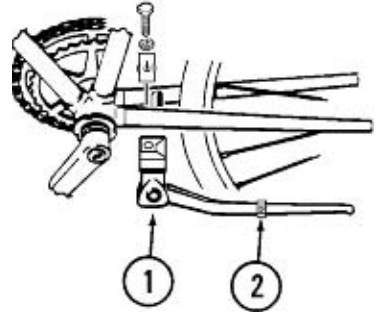

Rear Mount

- Attach the kickstand to the left side of the bicycle frame
Tubes near the rear axle
- Tighten hardware securely.



Brake Systems

For safe riding it is crucial that your bicycle's brakes function correctly. With use the bicycle's brake pads wear and the control cables stretch. Consequently, prior to every ride the brakes should be inspected and adjusted as necessary to ensure proper operation



WARNING: A bicycle should never be ridden unless the brakes are working correctly.

Take care when using the front brake. Applying it abruptly or excessively may throw the rider over the handlebars, potentially causing serious injury.

Hand Controlled brakes.

Operation

There are a number of different hand controlled brakes used on bicycles, all are operated by the rider squeezing the control lever attached to the handlebar. The brake lever pulls on a cable that is attached to the brake. The brake squeezes the rim between two brake shoes.

Determine which brake you have and following these instructions.

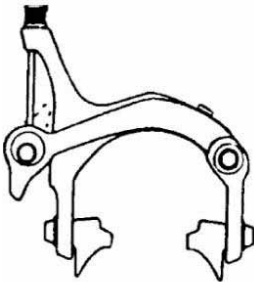

Side Pull Brake

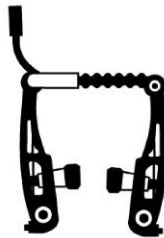

Linear

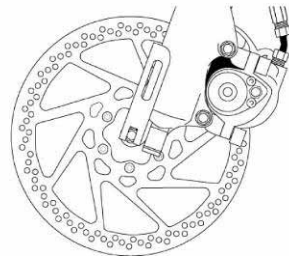

Disk Style Brake System

Inspection

The brake levers and the brake pads are the two main components that need to be checked to ensure they are functionally correctly.

Prior to every ride inspection of the brake pads is recommended. The brake pads must be centered, with approximately 1.5mm-2mm clearance between each pad and the rim when the brakes are not in use. Test that when the brakes are applied that the brake pads squeeze the rims sufficiently to stop the bike. Replace the brake pads if the grooves or pattern has worn away from the surface. Ensure the brake pads are firmly secured before every ride and at least every three months check the tightness of the numerous bolts and nuts supporting the brake pads.

Adjustments before riding



WARNING: You must adjust your front and rear brakes before riding.

1. Put the brake shoes in the correct position:

- Loosen the nut (10) of each brake shoe
- Adjust each brake shoe so it is flat against the rim and aligned with the curve of the rim
- Make sure each brake shoe does not rub the tire
- If the surface of the brake shoe has arrows, make sure the arrows point toward the rear of the bicycle
- Hold each brake shoe in position and tighten the nut.

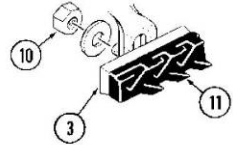

2. Test the tightness of each brake shoe:

- Try to move each brake shoe out of position
- If a brake shoe moves, do Step 1 again, but tighten the nut tighter than before
- Do this test again, until each brake shoe does not move.

3. Stretch the cable:

- Hold both brake shoes against the rim
- Loosen the cable clamp
- Pull the cable tight and tighten the cable clamp

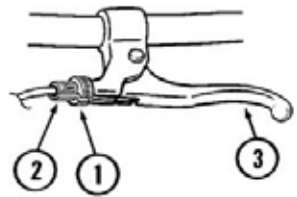

WARNING: Do not over tighten the cable clamp. Over tightening the cable clamp may cut the cable and cause injury to the rider or to others.

- Squeeze each brake lever firmly 20 times
- Hold both brake shoes against the rim and loosen the cable clamp
- Pull the cable tight and tighten the cable clamp

Lubrication (caliper brakes)

Lubricate the brake lever and the caliper pivot at least every three months with 2-3 drops of light oil. This will help to limit the wear and tear and ensure smooth operation. At least every six months remove the cables from their casings and grease along the entire length. Prior to fitting any new cable, always apply grease.

Adjustments – Sidepull calipers

To make minor brake adjustments use the barrel cable adjuster, usually found at the upper cable arm. Use the following outline as a guide.

1. Squeeze the brake pads against the rim and loosen the lock nut.

2. Set the adjuster so there is approx 1.5mm-2mm clearance between the brake pedal and the rim.

3. Re-fasten the lock nut

If the clearance between the brake pad and the rim cannot be set to 20mm or less using this method, the cable length may need to be adjusted.

To do this

1. Screw the barrel adjuster in completely.

2. Press the pads against the rim.

3. Un-fasten the cable anchor bolt and use pliers to pull the cable through.

4. Re-fasten the cable anchor bolt.

5. Test the brake lever by applying full force, and the barrel adjuster to make any needed minor alterations.

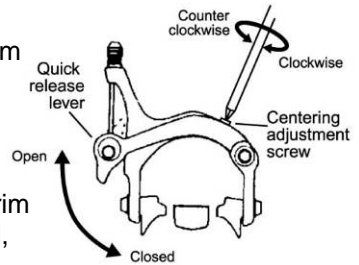

Cable adjustment bolt

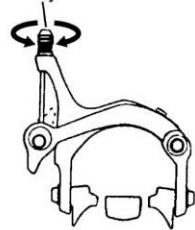

Reducing Caliper Brake Noise (Caliper Brake Only)

NOTE: The leading edge of the brake pads should make first contact with the rim when the adjustment is complete.

It is common for caliper brakes to make noise or “squeak” when in use. The noise may be reduced by following the instructions below:

- Make sure the caliper brakes are adjusted correctly
- Using a small adjustable wrench, bend each caliper arm so the front edge of each brake shoe is the first part to touch the rim

Installation and Adjustment – Linear Pull Brakes

1. When assembling linear pull brakes, insert the brake body into the center spring hole in the frame mounting boss, and use the link fixing bolt to fasten the brake body to the frame.

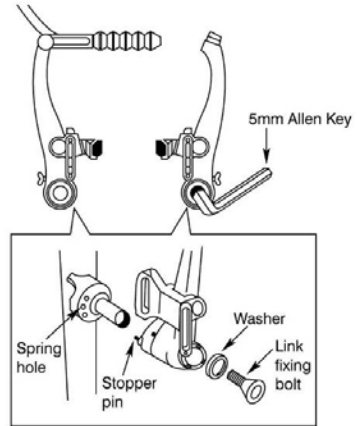

2. Hold the shoe against the rim and swap the position of the 6mm and 3mm B washer so that A is maintained at 39mm or more. (Refer to the following diagram for clarification.)

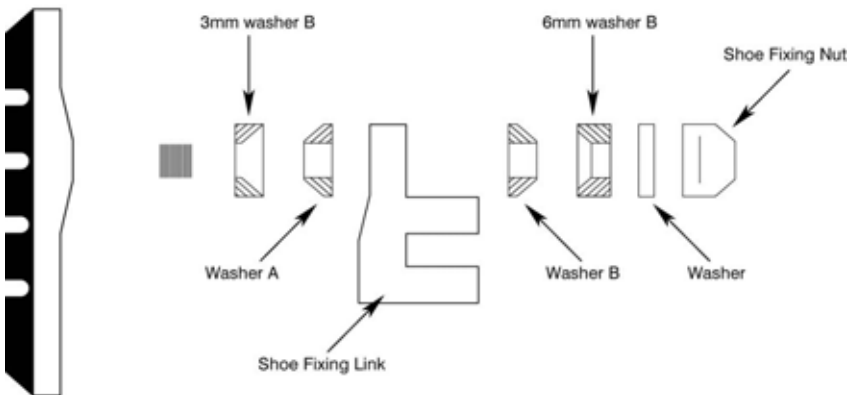

3. Fasten the shoe fixing nut while holding the shoe against the rim.

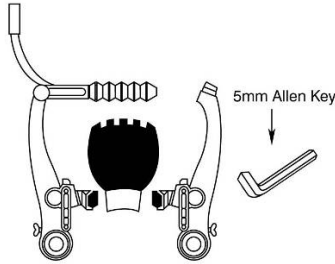

4. Thread the inner cable through the inner cable lead. When a clearance of 1mm between each brake pad and the rim is achieved, secure the cable fixing bolt.

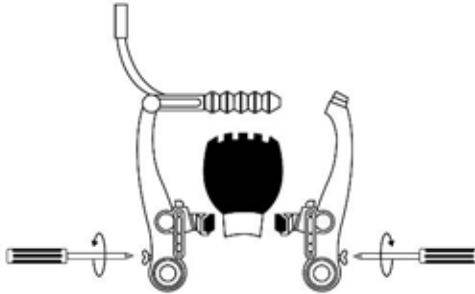

5. Alter the spring tension adjustment screws to connect the balance.

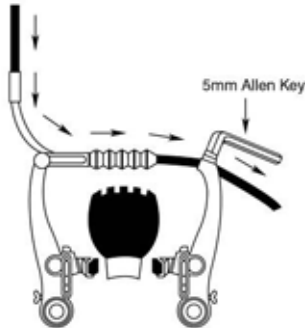

6. Check the brake operation and shoe clearance by fully squeezing the brake lever repeatedly, (about 10 times). Loosen and then re-fasten the cable fixing bolt as per Step 4 until adjustment is correct. Make any fine alterations via the adjusting screw at the brake lever.

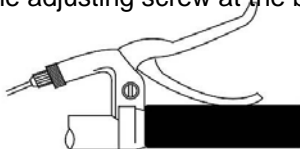

Installation and Adjustment – U-Brake

To install U-Brakes:

1. Lubricate the contacting surfaces of the frame bosses and the brake arm attaching area.
2. Secure the spring to the hole on the brake arm, spring cover and fixing arm nut.
3. Fasten the attaching bolt with a 5mm Allen key wrench to a torque of 6 Nm to 8 Nm. Note: The spring winds in different directions for the right and left arms. (See Fig.1)

When adjusting brake shoes, the brake arm needs to be able to move freely.

To Adjust and secure brake shoes:

1. Attach the brake shoe so the direction of the arrow sign is the same as the rim rotation direction.
2. Set the straddle cable as in Fig.1, and alter the shoe-rim until a clearance of 1.5mm on both sides is achieved.
3. Fasten the straddle cable with the cable fixing nut to a tightening torque of 5 Nm to 7Nm
4. Trim the excess straddle cable and connect the cable cap.

Refer to Fig. 1 to help you fine tune the shoe clearance. You will need a 13mm wrench to make adjustments.

1. If A in Fig.1 is greater than B, (the left side), turn the arm fixing nut anti-clockwise (in the A direction)
2. If B is greater than A (the right side), turn the fixing nut clockwise (in the B direction).

To make fine adjustments of the spring tension

refer to Fig. 1 and use a 13mm wrench to:

1. Tighten the spring tension, turn the arm fixing but to A and A' as in Fig.1.
2. Loosen the spring tension, turn to B and B'.

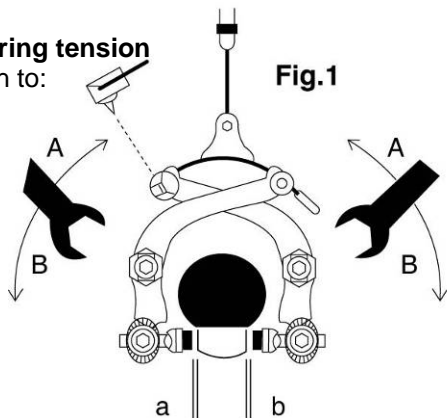

Brake pad replacement

Check your brake pads monthly for any indication of wear. If the pads are worn past the “wear line” indication the brake shoes need to be replaced. Always replace in pairs, never one side only.

Disconnect the holding mechanism specific to your brake type. Remove the worn brake pad shoes paying careful attention to the order and position in which the various curved washers and spacers attached. Fit the new brake pads, and tune the angle and the clearance to the rims as required. Normally before the rim clearance can be adjusted the control cable anchor bolt needs to be loosened and then the cable adjusters fasten and the cable tensioned. (Refer to previous steps).

Once adjustments are complete, securely fasten the brake pads in place and test that the brakes are functionally correctly.



WARNING: Don't ride bicycle until the brakes are working effectively.

Disc Brakes

WARNING - Don't ride the bike until the brakes are functioning correctly.

WARNING: DISC GETS HOT! Severe injury could result from contact with the hot disc! Mind your legs, as well as your hands and don't adjust directly after riding.

Don't return the bicycle to the store if you can't adjust the disc brakes. Please call our service team on 1800 632 792.

Disc Brakes

If fitted with a front disc brake, the components should already be attached. However, please check all connections before attempting to ride the bicycle. Secure tightly the 6 bolts that hold the disc to the wheel hub (E) and the 2 bolts that hold the brake mechanism to the fork (F).

Insert the front wheel into the fork dropouts ensuring that the disc fits into the brake mechanism between the enclosed brake pads. Secure the front wheel to the bicycle by tightening the bolts or quick release mechanism depending on what your bicycle is equipped with.

The cable to the brake lever should already be attached, but please double check it is positioned correctly. The cable should be in the cable end holder and then through the barrel adjuster and lock nut. Ensure that the barrel adjuster and lock nut are rotated so the slots no longer line up. Ensure the cable housing seats appropriately into the end of the barrel adjuster and check for any kinks or damage.

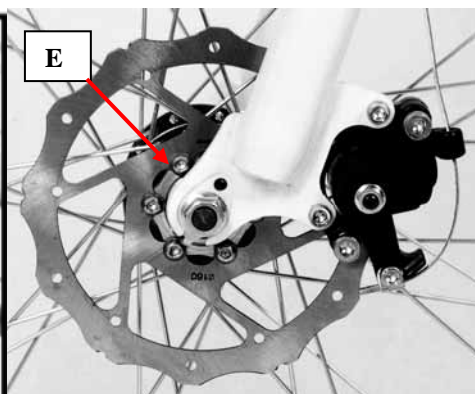
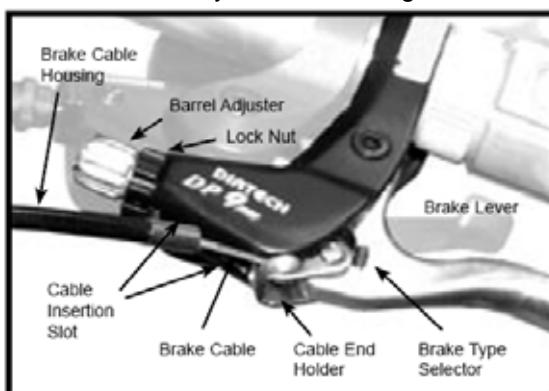

These brakes require breaking in!

Please be aware that the brake pads may slightly rub on the disc rotor, even after adjustment. This is due to the fact that the brakes are required to be worn in.

Ride and use the brakes gently for at least 20km before using the brakes in downhill conditions, for sudden stops or any other serious braking.

Please be aware that your brake system will change in performance throughout the wear-in process. The disc brake should be cleaned before the first ride using rubbing alcohol. NEVER use oil or similar products to clean your disc brake system.

Disc Brake Adjustment

To adjust the distance between the pads and disc

Loosen the cable anchor bolt (A) and hold the end of the cable.

Move the calliper arm approximately 1/8 of a turn anti-clockwise, or until pads almost make contact with the disc brake rotor (C) and re-tighten the cable anchor bolt (A).

To test apply the brakes while trying to push the bike forward to ensure the brakes will stop the bike.

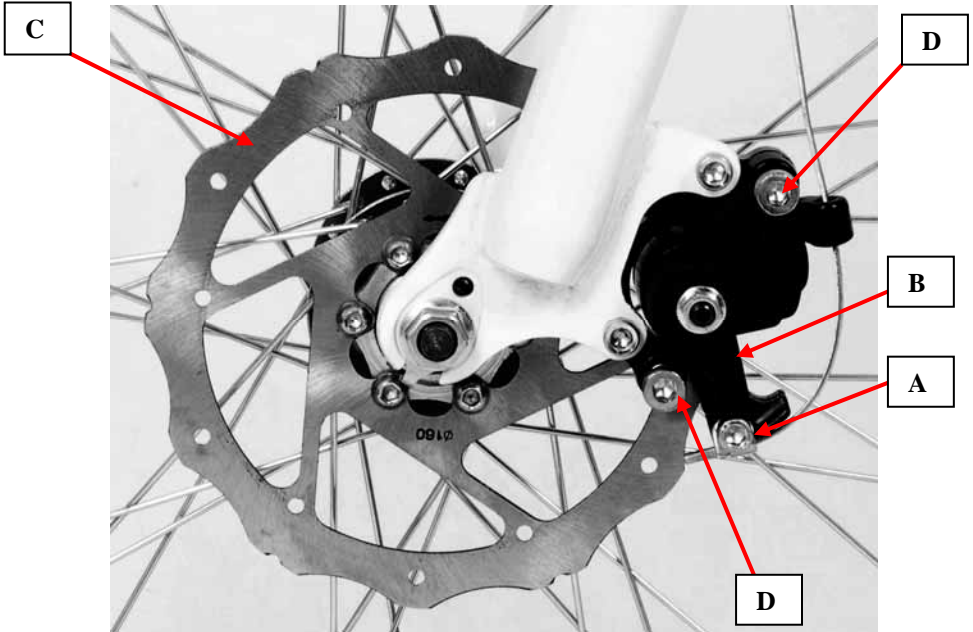

To adjust angle of pads

The angle of the pads in relation to the disc rotor (C) can be finely adjusted by the two adjusting bolts (D). Turning the adjusting bolts with an Allen Key clockwise or counter clockwise will increase or decrease the distance of the pad from the disc. Select the correct position where the pads have even contact with the disc when brake lever is pressed.

Gears: How to Operate

Derailleur gears are the most common type of gear systems used on bicycles. They are the changing mechanism used to move the drive chain up and down a series of cogs or sprockets at the rear of the bicycle and across the chain wheel at the front of the bike (if fitted).

The right shifter works the rear derailleur and the left shifter works the front derailleur. If the pedals are stationary or rotating backwards, gears cannot be changed, they can only be changed while pedaling forward.

Generally the lower gears are for the ascending hills and the higher gears are for descending.

Operating the shift system

- The turns the rear shift control around the handlebar (for twistshift models) or moves the shift lever (thumbshift models) to an index position
- When the rear shift controls moves into each position with a ‘click” sound, the shift is complete
- The rider turns the front shift control around the handlebar (for twistshift models) or moves the shift lever to an index position (thumbshift models)
- Each shift control pulls a cable wire that is attached to the derailleur
- The derailleur moves and guides the chain from one sprocket to another
- The number of gear changes to occur at any time corresponds with how many turns you made of the shifter.
- If there is some chain noise after the shift, turn the rear shift control a small amount to “trim” the rear derailleur.



CAUTION: Do not force the shift levers. Shift only when pedaling forward and without strong force. Do not back pedal. Back pedaling can cause the chain to come off the sprockets. Back pedaling and shifting while not pedaling can damage the sprockets and stretch the cable wire.

There is no “correct gear” in which to ride the bicycle. The “correct gear” is the one that is comfortable to you. To select a gear or sprocket combination while riding:

- While pedaling, shift the chain onto different front and rear sprocket combinations.
- You will feel a difference in the rhythm and ease of pedaling.

- When riding uphill or against the wind you may wish to keep the chain on the smallest front sprocket (1) and shift the chain on the rear sprocket (2).

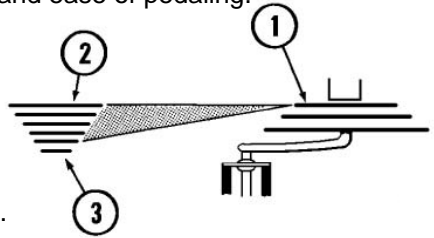

- These are the lower gear combinations.
- They allow you to pedal easier and at a faster rhythm, but with less distance traveled per pedal revolution.
- For the best performance in this case, do not use the smallest rear sprocket (3).

- When riding downhill or with the wind, you may wish to keep the chain on the largest front sprocket (4) and shift the chain on the rear sprocket cluster

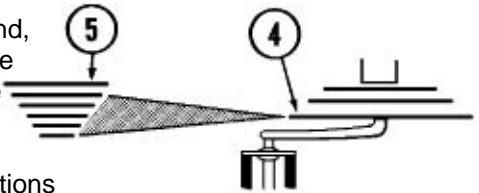

- These are the higher gear combinations
- They allow you to pedal harder and at a slower rhythm, but with more distance traveled per pedal revolution
- For best performance in this case, do not use the largest rear sprocket (5)

- On bicycles with three front sprockets, you may wish to keep the chain on the middle front sprocket (6) and shift the chain on the rear sprocket cluster

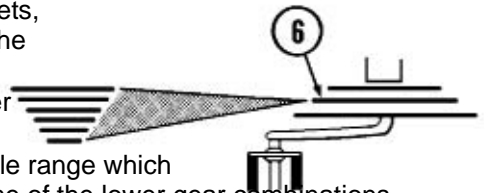

- These gear combinations are middle range which overlap some of the higher and some of the lower gear combinations.

General Adjustments

These instructions describe most adjustments that the shift system may need. If you can not adjust the shift system using these instructions, have a bicycle service shop do the adjustments that are needed.

The front derailleur has two adjusting screws. The “low” adjusting screw, sometimes marked “L” limits how far the front derailleur and chain can move toward the frame. The “high” adjusting screw, sometimes marked “H” limits how far the front derailleur and chain can move away from the frame.

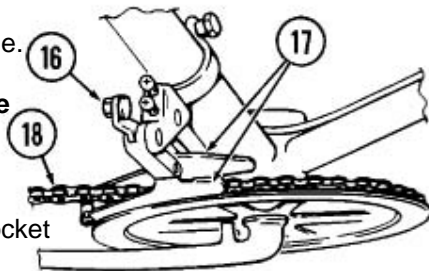

1. Put the “low” adjusting screw in the correct position as follows:

- Shift the chain onto the third largest rear sprocket and the smallest front sprocket
- Loosen nut of the cable clamp (16)
- Turn the “low” adjusting screw so the left inside edge of the chain cage (17) and the chain (18) just do not touch
- Remove the slack from the cable wire and tighten the nut of the cable clamp.

2. Put the “high” adjusting screw in the correct position as follows:

- Shift the chain onto the largest front sprocket and the smallest rear sprocket
- Turn the “high” adjusting screw so the right inside edge of the chain cage and the chain just do not touch.

NOTE- If the shift lever does not move easily:

- If the shift cable seems to stick, lubricate it
 - Do not lubricate the shift control
 - If the shift cable is sharply bent, rusted or has broken strands, replace it.
- Do the “Rear Derailleur Adjustments” if:
- The chain will not shift onto all the rear sprockets
 - The chain comes off the rear sprockets
 - The chain makes noise while on the smallest or largest rear sprocket
 - The rear derailleur (5) rubs the spoke protector

Rear Derailleur Adjustments

The rear derailleur has two adjusting screws. The “low” adjusting screw, sometimes marked “L”, limits how far the rear derailleur and chain can move toward the wheel. The “high” adjusting screw, sometimes marked “H”, Limits how far the rear derailleur and chain can move away from the wheel.

1. Put the “high” adjusting screw in the correct position as follows:

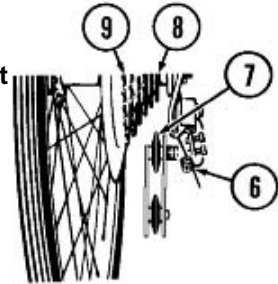

- Shift the chain onto the smallest rear sprocket
- Loosen nut of the cable clamp (12)
- Turn the “high” adjusting screw so the jockey roller (7) is in line with the outside edge of the smallest rear sprocket (8)
- Remove the slack from the cable wire and tighten the nut of the cable clamp.

2. Put the “low” adjusting screw in the correct position as follows:

- Shift the chain onto the largest rear sprocket
- Loosen nut of the cable clamp
- Turn the “low” adjusting screw so the jockey roller is exactly below the largest rear sprocket (9)
- Tighten the nut of the cable clamp.

3. Adjust the index shift system:

- Shift the chain onto the smallest rear sprocket
- Without turning the crank, turn the shift control one “click”
- Slowly turn the crank forward
- The chain should move from the smallest rear sprocket to the next larger rear sprocket
- Turn the adjusting barrel as needed so the chain moves exactly on to the second rear sprocket and does not rub, jump, or delay.

Chain

Inspection and Lubrication

Regular inspection and maintenance of your chain is vital to guard against premature wear. At least monthly, or after riding in wet, muddy or dusty conditions, the chain should be cleaned and lightly oiled. Any excess oil should be removed and care taken to ensure lubricant does not come in contact with tyres or rim braking surfaces. Check that all links of the chain move freely. Replace the chain if it appears stretched, broken or causes problems when changing gears.

Adjustment and Replacement

Note: Fitting or adjusting a chain can be a complex task and one which you may wish to refer to your local bicycle specialised.



WARNING: This bicycle has special high strength chain. Do not use a pliers type chain tools to remove the chain. Separate the chain only at an original pin (10). Never separate the chain at the master link (11) or at a connecting link (12). Identify an original pin by either two lines or a square on each end, a master pin by plain ends, and a connecting pin by an indentation on one end. If you remove an original pin from the chain, discard it. Use only a new connecting pin to assemble the chain. If you have any questions, contact Hyper-extension. If you do not obey these instructions, chain failure can result and cause injury to the rider or to others.

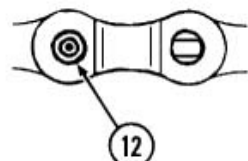
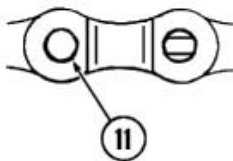
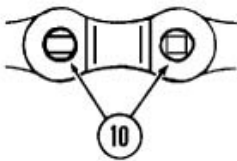

Bicycle Care and Maintenance

Routine bicycle maintenance is an essential component of riding. The condition of your bicycle changes every time it is used, meaning more frequent maintenance is necessary the more you ride your bicycle. The tables listed below outline the recommendations for servicing your bicycle. By referring to these and the information in other sections of this manual, you should be able to complete most of your bicycle maintenance yourself. Contact your specialist bicycle dealer if you require further assistance.

Lubrication

What	When	How
Derailleurs	every month	Put one drop of oil on each pivot point
Brake Levers	every month	Put one drop of oil on the pivot point
Chain	every month	Put one drop of oil on each roller.
Caliper Brakes	every month	Put two drops of oil on the pivot point
Cantilever Brakes	every 6 months	Put two drops of oil on the pivot point
Brake and shift Cable	every 6 months	Put four drops of oil into both ends. Allow oil to soak back along the cable wire
Pedals into the pedals	every 6 months	Put four drops of oil where the axles go into the pedals
Rear Sprocket Cluster	every 6 months	Lay bicycle on it's left side. Slowly turn the rear wheel clockwise. Put four drops Oil in the gap between the rear sprockets and the freewheel body
Suspension	every 6months	Lift up the rubber fork boot and dab a Small amount of grease on the fork leg Just above the plastic bushing.
Wheel bearings	Yearly	lithium based grease
Headset	Yearly	lithium based grease
Seat pillar	Yearly	lithium based grease

Use a light machine oil to lubricate your bicycle.

Note:

- Increase the regularity of maintenance the more you ride and use in wet or dusty conditions.
- Take care not to over lubricate – excess lubricant should be removed to prohibit dirt build up.
- The chain can throw excess oil onto the wheel rims, wipe excess oil off chain.



WARNING:

Always seek expert advice for any maintenance requirements you feel unable to complete. You run the risk of potentially damaging your bicycle or yourself from falling if your bike is not correctly serviced or adjusted.

Service Checklist

<u>Frequency</u>	<u>Task</u>
Before every ride	Check tyre pressure Check brake operation Check wheels for loose spokes Make sure nothing is loose
After every ride	Quick wipe down with damp cloth
Monthly	Lubrication as per schedule 1 Check derailleur adjustment Check brake & gear cable adjustment Check tyre wear and pressure Check wheel are true and spokes tight Check hub, head set and crank bearings for looseness Check pedals are tight Check handlebars are tight Check seat and seat post are tight



WARNING:

All components of the bicycle are subjected to wear and stress through use. Watch closely for any scratches, cracks or discolouration on your bicycle components. These are signs of a stress-caused fatigue and indicate that a part needs to be replaced. Failure to replace can cause the component to suddenly fail when riding, which may result in serious injury or even death.

Recommended Torque

Nuts and bolts should be adjusted using a torque wrench. This helps to prevent over tightening and damage to the threads. Different torque measurements are recommended when tightening different components. Use the following table as a guide.

Component	Torque (N.m)
Front axle nuts	22-27
Rear axle nuts	24-29
Stem Bolt expander bolt	17-19
Handlebar clamp	17-19
Post clamp	12-17
Seat clamp	15-19
Pedals	24-30
Brake cable fixing nut	7-11
Brake caliper centre bolt/nut	2-17
Brake shoes	5-10

Tyres

Frequently check the tyre inflation pressures because all tyres lose air slowly over time. For extended storage, keep the weight of the bicycle off the tyres.

Inflation: Maintain tyre pressure at the level recommended on the tyre sidewalls.

Conversion from PSI to kilopascals is listed below.

PSI	Kilopascals
1	6.895
20	138
30	207
40	276
50	345
60	415

Maintenance

Frequently check the tyre inflation pressure because all tires lose air slowly over time. For extended storage, keep the weight of the bicycle off the tyres.



WARNING: Do not ride or sit on the bicycle if either inner tube is under inflated. This can damage the tyre and inner tube. Do not use unregulated air hoses to inflate the inner tubes. An unregulated hose can suddenly over inflate bicycle tyres and cause them to burst.

Use a hand or a foot pump to inflate the inner tubes. Service station meter-regulated air hoses are also acceptable. The correct inflation pressure is shown on the tire sidewall. If two inflation pressures are on the tyre sidewall, use the higher pressure for on-road riding and the lower pressure for off-road riding. The lower pressure will provide better tire traction and a more comfortable ride.

Before adding air to any tyre, make sure the edge of the tyre (the bead) is the same distance from the rim, all around the rim, on both sides of the tyre. If the tyre does not appear to be seated correctly, release air from the inner tube until you can push the bead of the tyre into the rim where necessary. Add air slowly and stop frequently to check the tyre seating and the pressure, until you reach the correct inflation pressure.

Replace worn or defective tyres and inner tubes.

Suspension Frame (on some models)

Adjustments

The bicycle may have an adjustable shock-absorbing suspension. You can change the suspension, as you prefer, for a softer or a firmer ride.

To change the suspension:

- For a softer ride, turn the adjusting nut (1) clockwise so the suspension spring (2) is compressed less
- For a firmer ride, turn the adjusting nut counter clockwise so the suspension spring is compressed More.

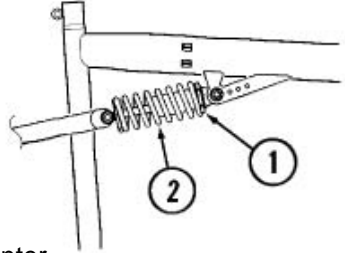

Three – Piece Crank (on some models)

Maintenance

Both three-piece crank arms (1) were tightened to the spindle (2) at the factory. After riding the bicycle the first few times, Make sure the crank arms have not loosened.

If either crank arm has loosened during this “break-in” period, have it tightened by a bicycle service shop, because special tools are necessary.

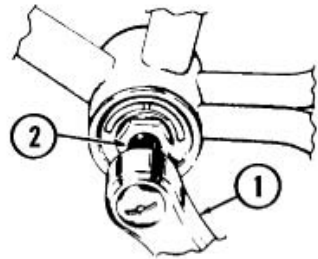

Frequently check the tightness of the crank arms. If loose, have them tightened by a bicycle service shop.

Inspection of the Bearings

Maintenance

Frequently check the bearings of the bicycle. Have a bicycle service shop lubricate the bearings once a year or any time they do not pass the following tests:

Head Tube Bearings

The fork should turn freely and smoothly at all times. With the front wheel off the ground, you should not be able to move the fork up, down, or side-to-side in the head tube.

Crank Bearings

The crank should turn freely and smoothly at all times and the front sprockets should not be loose on the crank. You should not be able to move the pedal end of the crank from side-to-side.

Wheel Bearings

Lift each end of the bicycle off the ground and slowly spin the raised wheel by hand. The bearings are correctly adjusted if:

- The wheel spins freely and easily
- The weight of the spoke reflector, when you put it toward the front or rear of the bicycle, causes the wheel to spin back and forth several times
- There is no side-to-side movement at the wheel rim when you push it to the side with light force.

Suspension Fork

The fork should slide freely up and down through its travel. If it is sticking, lift up the rubber boot over the fork legs and dab a small amount of grease on each leg just above the plastic bushing.

There should not be excessive looseness in the fork leg bushings. Stand beside the bike and gently apply the front brake. Rock the bike back and forth to check for excessive looseness in the fork bushings. Take the bike immediately to a dealer for inspection if excessive looseness is apparent.

Replacement Part Order List

To order warranty replacement parts, call us at (E.S.T) 1-800-632-792. To order the correct part, refer to the model number stamped on the inside cover of this manual and substitute it for the "xxxxx" below in our Part Number system. For example, if your model number from the inside front cover is #28206 and you need a new seat, order Part Number 28206-SD. Note- Your model may not look exactly like the representative picture shown.

Key Number	Part Number	Description
1	xxxxx-FR	Frame
2	xxxxx-FK	Fork
3	xxxxx-BRGHD	Head Bearing Set
4	xxxxx-BRGCR	Crank Bearing Head
5	xxxxx-WHF	Front Wheel
6	xxxxx-WHR	Rear Wheel
7	xxxxx-TR	Front or Rear Tyre
8	xxxxx-TU	Front or Rear Inner Tube
9	xxxxx-ST	Stem
10	xxxxx-HB	Handlebar
11	xxxxx-GR	Grips
12	xxxxx-HDRB	Front Brake Lever
13	xxxxx-CALR	Rear Caliper Brake
14	xxxxx-BC	Rear Brake Cable & Sheath
15	xxxxx-HDFB	Rear Brake Lever
16	xxxxx-CALF	Front Caliper Brake
17	xxxxx-BC	Front Brake Cable and Sheath
18	xxxxx-SHR	Rear Shift Control and Cable
19	xxxxx-DRR	Rear Derailleur
20	xxxxx-SCR	Rear Shift Control Sheath
21	xxxxx-SHL	Front Shift Control and Cable
22	xxxxx-DRF	Front Derailleur
23	xxxxx-SCF	Front Shift Control Sheath
24	xxxxx-SP	Seat Post
25	xxxxx-SD	Seat
26	xxxxx-RK	Reflector Kit
27	xxxxx-CH	Chain
28	xxxxx-SR	Spoke Protector
29	xxxxx-FW	Rear Sprocket Cluster
30	xxxxx-CR	Crank
31	xxxxx-PD	Pedals
32	xxxxx-SMCLHDW	Seat Post Clamp Hardware
33	xxxxx-AC	Quick Release Axle
34	xxxxx-TB	Bag
35	xxxxx-BO	Water Bottle Kit
36	xxxxx-HBENDS	Bar Ends
37	xxxxx-KS	Kickstand
38	xxxxx-HP	Handlebar Plug

Hyper-extension will make every attempt to find exact replacement parts for newly purchased bicycles. We cannot however, guarantee exact replacement parts or every part for older models.

Exploded Diagram

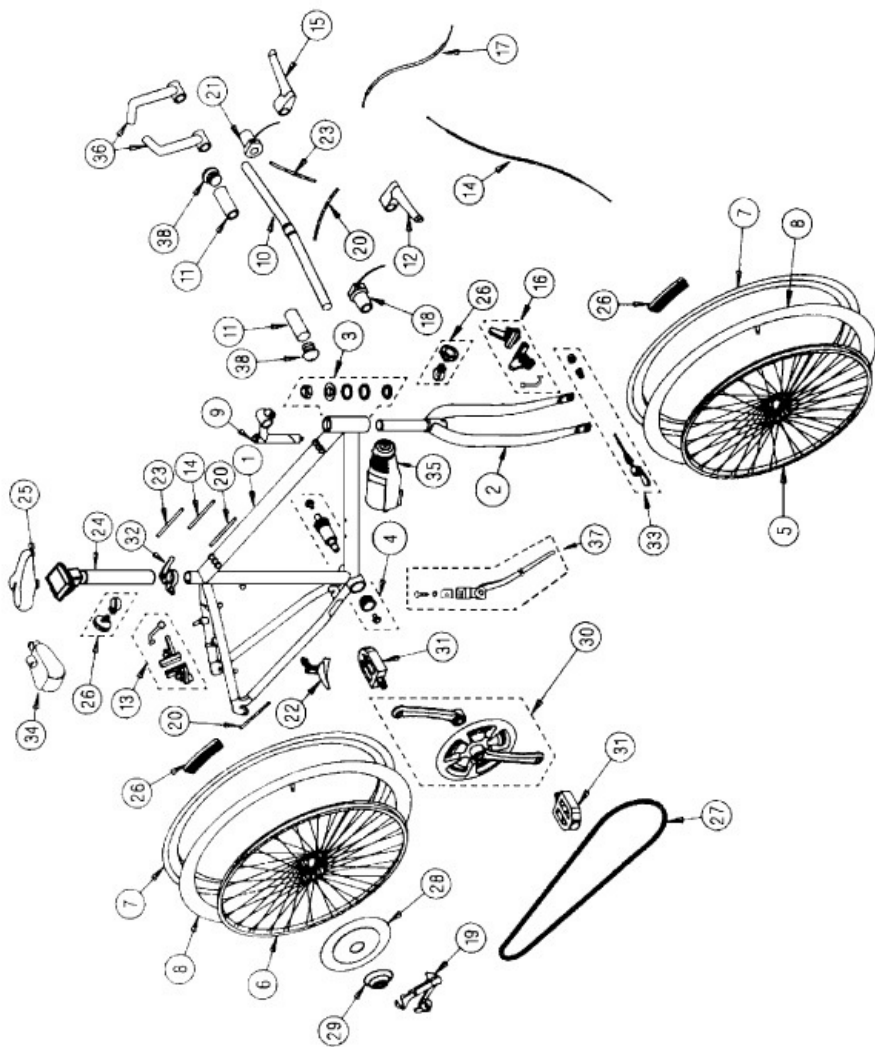

The Hyper-Extension Limited Warranty

All bicycles manufactured by Hyper-extension are warranted to the original purchaser to be free from defects in materials and workmanship for a period from the date of purchase.

- Lifetime for the bicycle frame
- 6 months on all other components/parts

This Limited Warranty is the only warranty for your bicycle. There are no other express warranties. The only uses for this product are described in this manual. This Limited Warranty extends only to the original consumer and is not transferable to anyone else.

What must you do to keep the Limited Warranty in effect?

This Limited Warranty is effective only if:

- The bicycle is completely and correctly assembled;
- The bicycle is used under normal conditions for its intended purpose (see the following section for excluded activities);
- The bicycle receives all necessary maintenance and adjustments.

What is not covered by the Limited Warranty?

The bicycle is designed for general transportation and recreational use only. This Limited Warranty does not cover normal wear and tear, normal maintenance items, or any damage, failure, or loss that is caused by improper assembly, maintenance adjustment, storage, or use of the bicycle. This Limited Warranty will be void if the bicycle is ever:

- used in any competitive sport;
- used for stunt riding, jumping, aerobatics or similar activity;
- installed with a motor or modified in any other way;
- ridden by more than one person at a time;
- rented
- used in a manner contrary to the instructions in this Owner Manual

Hyper-extension will not be liable for loss or damage, whether direct, indirect, special, or consequential due directly or indirectly from use of this product.

What will Hyper-extension do?

Hyper-extension will replace, without charge to you, any frame, fork, or component found to be defective by Hyper. The original owner must be pay all labour and transportation charges connected with the repair or warranty.

Note: Some warranty parts are of generic styling.